

# Development and Validation of Flat-Plate Collector Testing Procedures

Report for September – October, 2006

Focus on Energy (FOE) supports solar thermal systems that displace conventional fuels by offering cash-back rebates that provide an incentive for residents to invest in this renewable energy technology. To be eligible for rebates, FOE requires solar collectors to be certified by the Solar Rating and Certification Corporation (SRCC). The certification program involves testing of the solar collectors in accordance with ASHRAE Standard 93-2003<sup>1</sup>. Currently, these tests are only provided in Florida (outdoors) by the Florida Solar Energy Center (FSEC).

Wisconsin's flat plate collector testing program will be done at Madison Area Technical College (MATC). The UW-Solar Energy Laboratory is assisting MATC personnel in establishing a suitable implementation of the ASHRAE test method. The UW further intends to identify alternative test methods that can be done indoors or under conditions that are more suitable to Wisconsin weather, but still provide the information required by the ASHRAE 93-2003 test. What follows is the first report of this activity.

## Test configuration

The MATC solar collector test facility will use the open loop concept similar to Figure 1 shown below.

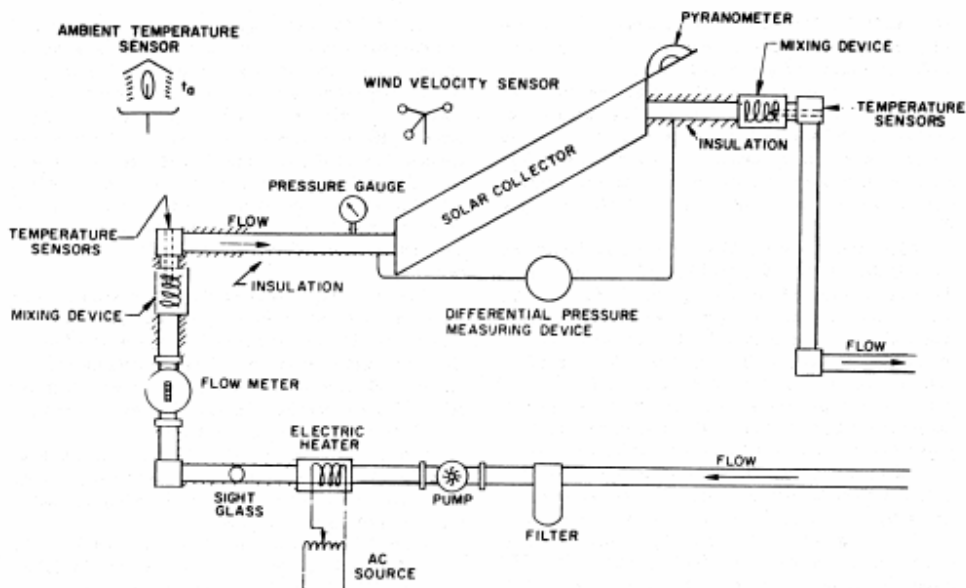
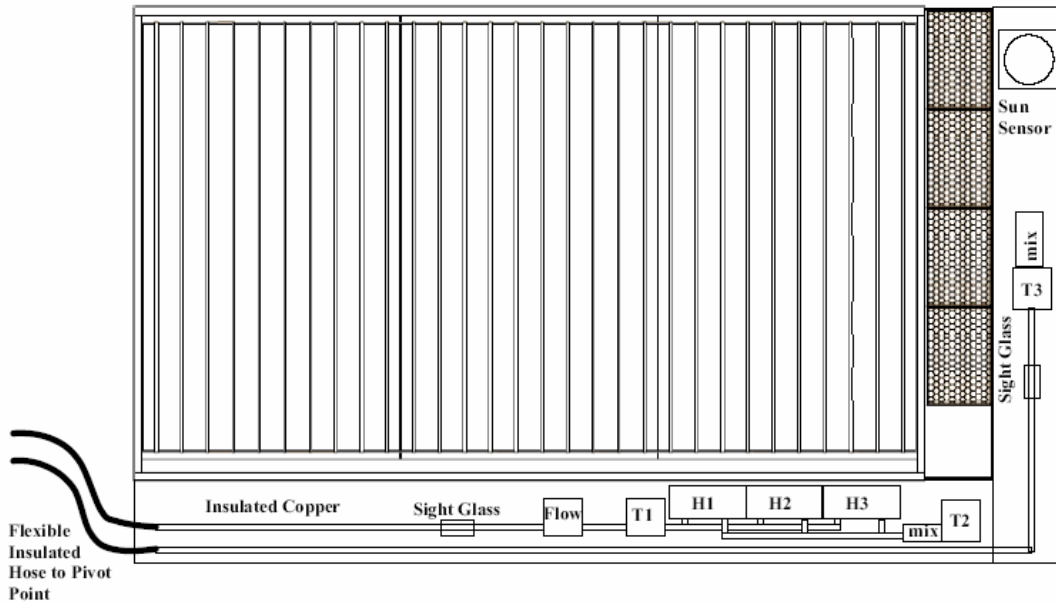

Figure 1 Open loop test configuration (from ASHRAE 93-2003 Figure 3)

The following figure shows the test setup as planned by the MATC.



**Figure 2** Test setup for collector tests at MATC (designed by Thomas Kaminski (MATC))

The flow plan for the setup in Figure 2 is shown in Figure 3 and it will be used to describe the test setup.

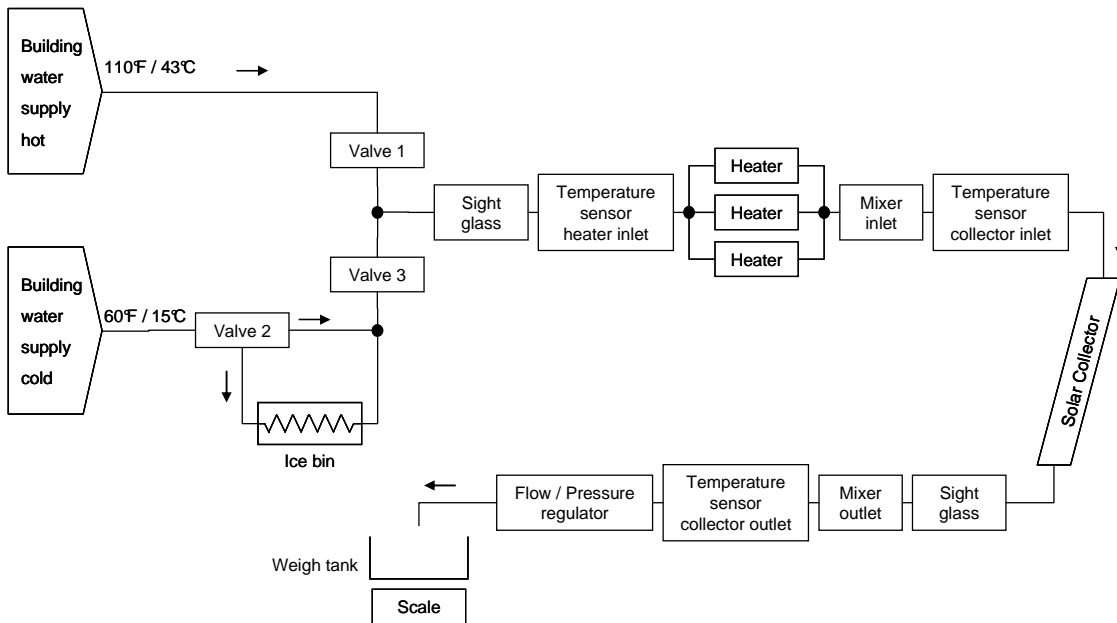

**Figure 3** Flow plan MATC collector test facility

Water will be used as heat transfer fluid. Instead of a pump, the building hot and cold water supply will provide suitable pressure to achieve the required fluid flow rates across the ranges expected. The temperature will be adjusted in two steps. First the valves will be used to roughly adjust the temperature by mixing hot and cold water; after that, electric heaters will precisely raise the temperature to the desired value. To achieve fluid inlet temperatures lower than the cold water supply, an ice storage unit with heat exchanger may be integrated into the test setup. This storage unit will allow the supply water to be cooled to the prevailing ambient temperature as-required during low temperature ambient conditions. Flow meter and temperature sensors measure the fluid flow rate through the collector and the temperatures of the water entering and leaving the collector, respectively. In addition to the flow meter, a weigh tank can be used as a primary measure of the water mass flow rate and/or to calibrate the flow meter. Total solar radiation is measured by a pyranometer mounted in the plane of the collector.

### **Instrumentation**

The ASHRAE collector test standard defines minimum requirements for all instruments used collecting data within the test facility (ASHRAE standard 93-2003, chapter 7). Table 1 outlines the needed instruments and required specifications. Radiation measurements and flow rates are discussed in more detail in the following sections.

Table 1: ASHRAE 93-2003 Instrument requirements (based on 6. Instrumentation)

<b>Radiation measurements</b>		
Pyranometer	Change of response due to variations in ambient temperature	<±1%
	Constant sensitivity within ±2% over the spectral range from 0.3 to 2.5 microns	
	Accuracy	±1%
	Time constant	< 5 sec
Pyrheliometer	Change of Response due to variations in ambient temperature	<±1%
	Constant sensitivity within ±2% over the spectral range from 0.3 to 2.5 microns	
	Time constant	< 25 sec
<b>Temperature measurements</b>		
Measurements	in accordance with ASHRAE Standard 41.1-1986 (RA 2001) <sup>2</sup>	
Temperature accuracy*	±0.5°C (+/- 0.9°F)	
Temperature Precision**	±0.2°C (+/-0.36°F)	
Temperature Difference accuracy*	±0.1°C (+/-0.18°F)	
Temperature Difference Precision**	±0.1°C (+/-0.18°F)	
Time Constant	thermocouples, thermopiles	less than one second
	resistance thermometers	less than ten seconds
<b>Pumps</b>		
Flow rate	Recommended: 0.02 kg / s m <sup>2</sup> or 14.7 lbm/[h□ft <sup>2</sup> ]	
<b>Flow meter</b>		
Accuracy for liquid flow rates	≤ ±1.0%	
<b>Pressure measurement</b>		
Accuracy for liquids	±3.5 kPa (±0.5 psi)	
<b>Elapsed Time</b>		
Accuracy	±0.20%	
<b>Wind velocity</b>		
Accuracy	±0.8 m/s (±1.8 mph)	
* Accuracy = The ability of the instrument to indicate the true value of the measured quantity.		
** Precision = Closeness of agreement among repeated measurements of the same physical quantity.		
Instruments and requirements for testing collectors using air were left out!		

## Mass flow and volume flow

The flow rate must be the same for all data points and maintained constant during the test periods. The volume flow rate should be maintained within  $\pm 0.005$  gpm (0.000315 l/s) to provide steady state conditions. The ASHRAE standard recommends a mass flow rate per unit aperture area (aperture means transparent frontal) of  $0.02 \text{ kg/s-m}^2$  ( $14.7 \text{ lbm/h-ft}^2$ ). The volume flow rate then depends on the properties of the heat transfer fluid used during the tests. For water at a temperature of  $20^\circ\text{C}$  ( $50^\circ\text{F}$ ), the flow rate per unit of collector area is shown in Table 2. This information is from ASHRAE 93-2003 standard: sections (6.3), (8.3.1.1.6), (8.3.3.3)

Table 2: **Volume flow rates for water at  $20^\circ\text{C}$  ( $50^\circ\text{F}$ ) as recommended by ASHRAE 93-2003**

Aperture area	Volume flow rate	Aperture area	Volume flow rate
$\text{m}^2$	$\text{m}^3/\text{s}$	$\text{ft}^2$	$\text{gpm}$
1.9	37	20	0.59
2.8	56	30	0.89
3.7	74	40	1.18
4.6	93	50	1.48
5.6	112	60	1.77
6.5	130	70	2.07
7.2	145	78	2.30
7.4	149	80	2.36
8.4	168	90	2.66
9.3	186	100	2.95
13.9	279	150	4.43
18.6	372	200	5.90

## Radiation measurements

The pyranometer measures the total incident solar irradiance per unit area normal to the collector plane. The sun tracking pyrheliometer measures the direct normal beam solar irradiance per unit area. One of the stations of the Integrated Surface Irradiance Study (ISIS) Network is located on the roof of the Engineering Research Building (ERB) in Madison. The measured radiation data are published on the internet the day following the measurement (except on weekends). ISIS calibrates the instruments which consist of pyranometers for total and diffuse radiation (with a tracked shade disk) and a pyrheliometer for beam radiation. In principle, it is possible to use radiation data from

ISIS for the collector test at MATC. The advantage would be to reduce costs for instruments and save working hours for calibrating and maintaining the instruments.

However, this is not an option for the total radiation measurement, as the standard explicitly mentions that the pyranometer must be mounted in the plane of the collector (7.1.3). A pyrliometer is required in the instrument section of the ASHRAE 93 standard, but the measurements of this instrument are not directly used in the test results. So using the ISIS data could be an alternative option to installing a new pyrliometer at the MATC test facility. As the pyrliometer is not needed to conduct the efficiency test, the installation of a new pyrliometer at the MATC test facility can be postponed until the use of ISIS beam radiation data is evaluated. Relevant chapters of the ASHRAE 93-2003 standard for this issue are: (6.1); outdoor test: (7.1.3), (8.3.1.1.1)-(8.3.1.1.3); indoor test: (7.3.2), (8.3.1.2.1)

### Inlet temperature distribution

The ASHRAE standard prescribes collector efficiency measurements at different inlet temperatures that require a distribution of inlet temperatures. The distribution of inlet temperatures is very important for the dimensioning of the heaters and coolers in the test facility. It turns out to be one of the requirements in the ASHRAE test standard that can not be satisfied by the test facility at MATC, as explained below. The reason is not the equipment at MATC but the unrealistic requirements of the ASHRAE standard. Because of these circumstances closer attention is paid to the inlet temperature distribution in the following paragraphs.

### Introduction to inlet temperature distributions

This section explains the motivation for using different inlet temperatures. The inlet temperature distribution is used during the thermal efficiency test. The result of the thermal efficiency test is an efficiency curve like those in Figure 4.

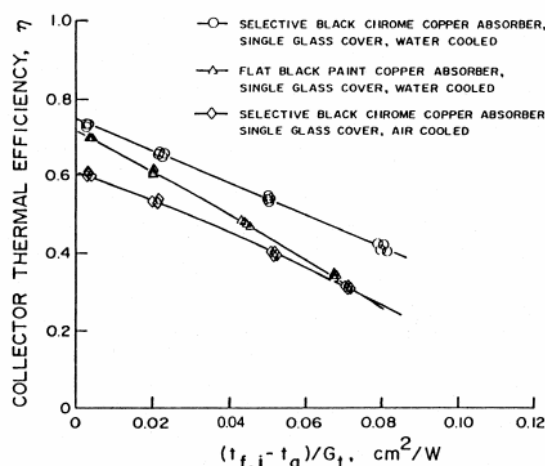

Figure 4 Examples of thermal efficiency curve, ASHRAE 93-2003 Figure 8

The important parameters from these tests are determined by the Y intercept A and the slope B of the test results plotted as efficiency versus x, where x is the ratio of the difference between inlet and ambient temperature and the total solar irradiance. Collector theory suggests that the efficiency is approximately a linear function of x and can be written as

$$y = A + Bx \quad (1.1)$$

where y is the efficiency value

$$y = \eta \quad (1.2)$$

and x is

$$x = \frac{t_{f,i} - t_a}{G_t} \quad (1.3)$$

If measurements are conducted for a certain value of x and the efficiency y for this value of x is measured, the values of x and y together are called a *data point*.

In theory, only two different values of x (or two data points) would be sufficient to describe the curve and calculate the Y intercept and the slope. This situation is illustrated in Figure 5.

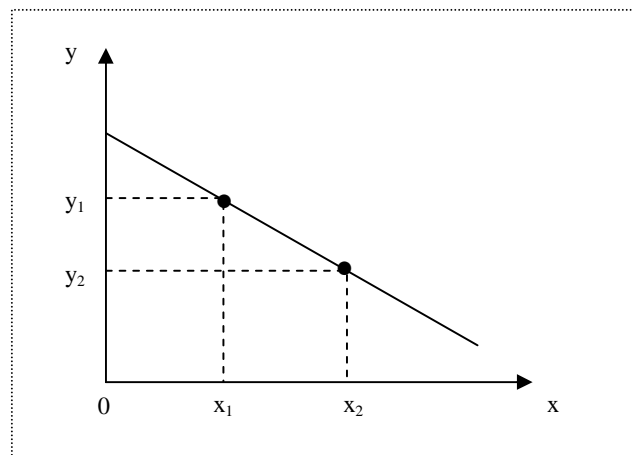

**Figure 5** Y intercept and slope derived from two data points

To increase the quality of the test results, the Standard requires conducting the test for four different values of x, which means for four different inlet temperatures (assuming ambient temperature and solar irradiance remain constant). Additionally, for every inlet temperature, 4 measurements are required. So finally the ASHRAE standard requires at least 16 data points for establishing the efficiency curve for a given collector. A plot is then created based on the 16 data points collected by using the standard technique of a least-square fit. The new situation is illustrated in Figure 6 and corresponds to the example curves in Figure 4.

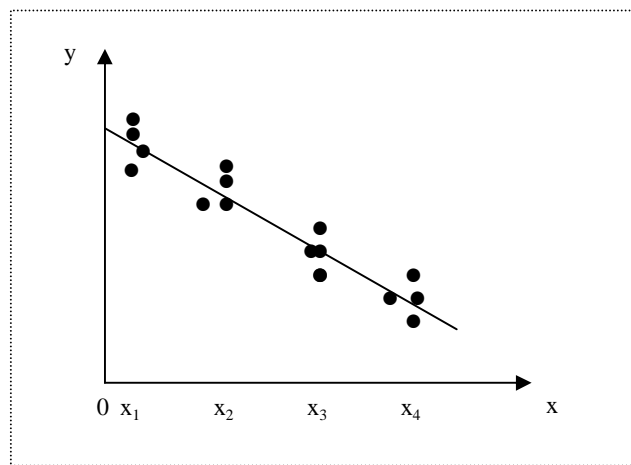

**Figure 6** Y intercept and slope derived from 16 data points

### **Inlet temperature distributions in the ASHRAE standard**

The distribution of the four different inlet temperatures can not be chosen arbitrarily. The ASHRAE standard allows only two distributions which will be described below. The first distribution described in chapter (8.3.3.1) of the standard is called “Distribution 1”, the second one ‘Distribution 2’.

#### **Distribution 1**

Distribution 1 uses the maximum operation temperature  $t_{max}$  recommended by the collector manufacturer. The inlet temperature distribution is determined by setting the difference between inlet and ambient temperature ( $t_{f,i} - t_a$ ) to 0%, 30%, 60% and 90% of the difference between maximum operation and ambient temperature ( $t_{max} - t_a$ ).

Advantages:

- Very easy
- Can be determined without any further information but the manufacturer’s recommended maximum operation temperature.

Disadvantages:

- The values of the calculated efficiencies might be distributed unequally over the range of possible efficiencies from 0 % to 100 %. It might even be possible to choose a temperature with a negative efficiency.
- The recommended temperatures are often that high, that distribution 1 leads to maxim inlet temperatures of far more than 100°C (212°F).

#### **Distribution 2**

Distribution 2 directly involves the efficiencies. At first the inlet temperature is adjusted to the ambient temperature. The efficiency for this inlet temperature is set to 100%. By

increasing the inlet temperature, the efficiency decreases as more heat losses to the surroundings occur. The temperature distribution is determined by decreasing the temperature until the thermal efficiency is reduced by 0%, 30%, 60% and 90%.

There are two ways to realize method 2:

- a. Calculate the instantaneous efficiency during the test and use the efficiency value to adjust the temperature indirectly.
- b. Use a model to calculate the temperatures and then adjust the inlet temperatures directly.

Advantages:

- The values of measured efficiencies are evenly distributed over the range from 10% to 100%.
- Using (b.) it would be possible to determine the complete temperature distribution before starting the efficiency test, as the 100% efficiency can be calculated from the measurements during the time constant test. Having the temperatures before the test will make the test processing easier, because the staff does not have to determine a temperature distribution during the test using (a.).

Disadvantages:

- Calculations are required to determine the distribution.
- For (b.) detailed information or estimations about the collector and the test conditions are needed.

### **Problems with the lower limit of the inlet temperature distribution**

Both distributions require setting one of the four inlet temperatures to ambient temperature. This measurements give directly the y-intercept ( $x = 0$  in Figure 6). Furthermore the standard does not allow extrapolating the curve. That means the only way to determine the y-intercept is by setting the inlet temperature to the ambient temperature. This works fine as long as the ambient temperature is above 16°C (60°F) which is the temperature of the cold water supply at the MATC building. But as soon as the ambient temperature becomes lower than the water supply temperature (approx. 10°C, 50°F), the water must be cooled. The ambient temperature is often below the water supply temperature in Wisconsin. Cooling can be provided by MATC. However, if the ambient temperature is lower than 0°C (32°F), water can no longer be used as heat transfer fluid. As changing the heat transfer fluid is not desirable, days with an ambient temperature significantly below 0°C (32°F) may not suitable for testing.

Another concern is that the ambient temperature may vary max. +/- 1.5°C (2.7°F). The inlet temperature must not be updated, but remain constant within +/- 2% or 1.0°C. (Chapter 8.3.3.3 in the ASHRAE standard). It appears then that the standard is inconsistent in what must be maintained constant, the inlet temperature or the temperature difference between the inlet and ambient.

The requirement to set the inlet temperature to the value of the outlet temperature increases the test effort for ambient temperatures between 16°C (60°F) and 0°C (32°F) and makes it impossible (using water as heat transfer fluid) below 0°C (32°F). UW plans to determine how many days during a typical year are available for testing when this and other requirements of the Standard (such as the available solar radiation) are considered.

### **Problems with the upper limit of the inlet temperature distribution**

The highest possible collector inlet temperature at the MATC facility is currently about 50°C (112°F). To reach this value the hot water supply of the building and heaters with a power of 12 kW are used. The most important question for the sizing of the heaters is: “What is the highest inlet temperature we have to provide during the collector test?”

The two allowed inlet temperature distributions introduced above set the highest inlet temperature to a value depending either on the manufacturer’s recommended maximum inlet temperature or on the efficiency curve of the collector. Using the data of previously-tested collectors, it is possible to calculate the inlet temperatures that would have been needed to test these collectors using one of the ASHRAE inlet temperature distributions. The highest inlet temperatures for both distributions are calculated below.

#### **Highest inlet temperature for distribution 1**

The maximum temperature in distribution 1 is determined by

$$(t_{f,i} - t_a) = (t_{\max} - t_a) \cdot 90\% \quad (1.4)$$

where  $t_{\max}$  is the maximum operation temperature recommended by the collector manufacturer. The maximum inlet temperature is then:

$$t_{f,i} = 90\% \cdot t_{\max} - 10\% \cdot t_a \quad (1.5)$$

So the maximum inlet temperature depends mainly on the manufacturer’s recommended maximum operation temperature. The manufacturer’s recommended maximum operation temperature for typical collectors on the market can be taken from “Directory of SRCC certified solar collector ratings (March 17, 2004)”. The range of recommended temperatures in this directory is shown in Table 3.

Table 3: Range of recommended maximum operation temperatures in “Directory of SRCC certified solar collector ratings (March 17, 2004)”

Collector type	Unglazed collectors	Glazed collectors	Vacuum tube collectors
Range of recommended maximum operation temperature $t_{\max}$ in °C	104	93.0	130
	132	99.0	
		100.0	
		100.0	
		120.0	
		121.0	
		121.1	
		132.0	
		140.0	
		170.0	
		176.7	
		177.0	
<b>Highest <math>t_{\max}</math></b>	<b>132</b>	<b>177.0</b>	<b>130</b>

Using distribution 1, the highest inlet temperatures would be required for the collector with the highest recommended temperature  $T_{\max}$ . The highest recommended temperatures are 132°C, 177°C, and 130°C for unglazed, glazed, and vacuum tube collectors respectively as shown in the last row of Table 3. As indicated in Equation (1.5), the inlet temperature depends also on the ambient temperature. Table 4 shows the required highest inlet temperature depending on the ambient temperature  $t_a$  for all three kinds of collectors.

**Table 4:** Range of required maximum inlet temperatures based on Table 3 and ASHRAE 93-2003 (8.3.3.1) first method

Collector type	$t_{max}$	$t_a$	$t_{f,i}$	$t_{a,EN}$	$t_{f,i,EN}$
	[C]	[C]	[C]	[F]	[F]
Vacuum tube	130	0	117.0	32.0	242.6
	130	5	116.5	41.0	241.7
	130	10	116.0	50.0	240.8
	130	15	115.5	59.0	239.9
	130	20	115.0	68.0	239.0
	130	25	114.5	77.0	238.1
	130	30	114.0	86.0	237.2
	130	35	113.5	95.0	236.3
	130	40	113.0	104.0	235.4
Unglazed	132	0	118.8	32.0	245.8
	132	5	118.3	41.0	244.9
	132	10	117.8	50.0	244.0
	132	15	117.3	59.0	243.1
	132	20	116.8	68.0	242.2
	132	25	116.3	77.0	241.3
	132	30	115.8	86.0	240.4
	132	35	115.3	95.0	239.5
	132	40	114.8	104.0	238.6
Glazed	177	0	159.3	32.0	318.7
	177	5	158.8	41.0	317.8
	177	10	158.3	50.0	316.9
	177	15	157.8	59.0	316.0
	177	20	157.3	68.0	315.1
	177	25	156.8	77.0	314.2
	177	30	156.3	86.0	313.3
	177	35	155.8	95.0	312.4
	177	40	155.3	104.0	311.5

Applying the first distribution recommended by ASHRAE to the glazed flat plate collector with the highest recommended inlet temperature in the “Directory of SRCC certified solar collector ratings (March 17, 2004)” would lead to a required inlet temperature of about 157°C or 315°F. This is an unreasonably high value. Our recommendation is not to use distribution 1, as the inlet temperatures required by many collectors on the market would be far too high for testing and these temperatures would not provide useful results if the testing facility were able to provide fluid at these conditions.

#### **Highest inlet temperature for distribution 2**

An overview of the required inlet temperatures using method 2 was obtained based on the “Ratings Summary of OG-100 certified glazed collectors” in the “Summary of SRCC certified solar collector and water heating system ratings (October 2006)”. The test results for a choice of collectors were compiled in order to calculate the required temperature difference. The efficiency curve of a collector is represented by the function (1.1), (1.2), and (1.3). The y intercept and the slope are given in the test summary for every tested collector. Collector models of the same manufacturer often have very similar efficiency curves. To get a representative choice of collectors, one or two collectors per manufacturer were chosen. Using distribution 2, the temperature distribution is determined by decreasing the temperature until the thermal efficiency is reduced by 0%, 30%, 60% and 90% from the intercept value corresponding to an inlet temperature equal to the ambient temperature. The highest inlet temperature is needed for the reduction by 90%. A reduction by 90% means an efficiency of 10% of the given y intercept, so

$$x = \frac{1.1 \cdot Y}{Slope} \quad (1.6)$$

and

$$t_{f,i} = \frac{x + t_a}{G_t}. \quad (1.7)$$

The maximum required inlet temperature for 42 collector models for an ambient temperature of 10°C (50°F) and solar irradiance of 800 W/m<sup>2</sup> were calculated on this basis. The results are presented in

Table 5.

Table 5: Choice of collectors in “Ratings summary of OG-100 certified glazed collectors” in the “Summary of SRCC certified solar collector and water heating system ratings (October 2006)” with an inlet temperature required for testing at an ambient temperature of 10C (50 F) and solar irradiation of 800 W/m<sup>2</sup>

Manufacturer	Model	Y intercept	Slope [W/m <sup>2</sup> -C]	t <sub>fi</sub> [C]
Rheem Water Heaters	RS21-BP	0.722	-8.36	86.0
Sealed Air Corporation	FW-48	0.739	-8.21	89.2
Radco Products, Inc	308P-HP	0.764	-7.51	99.5
Alternate Energy Technologies	AE-21E	0.660	-6.37	101.2
Synergy Solar	S19.78	0.626	-6.01	101.7
Sunsiary Solar Manufacturing, Inc.	NC-32	0.508	-4.84	102.4
Solargenix Energy, LLC	WS0503	0.600	-5.68	103.0
Radco Products, Inc	408P-HP	0.768	-7.24	103.3
Alternate Energy Technologies	ST-21E	0.674	-6.02	108.5
R&R Solar Supply	EPI-308CU(3'x8')	0.708	-6.11	112.0
Heliodyne, Inc.	Mojave 410	0.726	-6.08	115.1
Rheem Water Heaters	RS21-BC	0.759	-5.93	122.6
Solene	SLCR-30	0.735	-5.37	130.4
Synergy Solar	T19.78	0.647	-4.67	131.9
Alternate Energy Technologies	AE-21	0.706	-4.91	136.5
King Solar Products	KS-32	0.706	-4.91	136.5
Mr. Sun Solar	AE-40	0.706	-4.91	136.5
Solar Development, Inc.	SD8-28	0.706	-4.91	136.5
Solar Mining Company	SMC/AET26	0.706	-4.91	136.5
SunEarth, Inc.	EP-20	0.682	-4.54	142.2
Synergy Solar	TC-26.52	0.697	-4.57	144.2
Stiebel Eltron	Sol 25 Plus	0.660	-4.29	145.4
Rheem Water Heaters	RS21-SC	0.750	-4.87	145.5
Solahart Industries	Bt	0.750	-4.87	145.5
Solar Energy, Inc.	SE-21	0.704	-4.49	148.0

Radco Products, Inc	308C-HP	0.778	-4.96	148.0
ACR Solar International	10-01	0.602	-3.76	150.9
SunBank Solar	SB10	0.602	-3.76	150.9
Solar Capital Partners	Typ A	0.630	-3.88	152.9
Radco Products, Inc	408C-HP	0.779	-4.77	153.7
Schuco International KG	V, H, LA	0.718	-4.28	157.6
Solene	SLCO-30	0.782	-4.60	159.6
SunEarth, Inc.	EC-20	0.714	-4.13	162.1
Schuco International KG	V, LA	0.715	-3.99	167.7
Thermomax Industries Ltd.	AST20	0.574	-3.05	175.6
Viessmann manufacturing Company (US) Inc.	SV1, SH1	0.720	-3.50	191.0
Beijing Sunda Solar Energy Technology Co Ltd	SEIDO 5-16 AS/AB	0.492	-1.92	235.5
Beijing Sunda Solar Energy Technology Co Ltd	SEIDO 10-10AS/AB	0.462	-1.57	269.0
Beijing Sunda Solar Energy Technology Co Ltd	SEIDO 1-16	0.529	-1.70	283.8
Apricus Solar Co., Ltd.	AP-10	0.418	-1.17	324.4
Thermo Technologies	TMA-600-20	0.530	-1.42	338.5
Viessmann manufacturing Company (US) Inc.	Typ SP3, 2m2	0.509	-1.09	420.9

The results in Table 5 indicate that only three out of 42 collectors could be tested with an inlet temperature below 100°C or 212°F. 30 out of 42 collectors would need an inlet temperature above 130°C or 266°F to be tested with distribution 2. Just like distribution 1 distribution 2 leads to inlet temperatures above 100°C (212°F) which is not reasonable for testing a device that is used for low temperature applications.

### Conclusion and Recommendations

Both inlet temperature distributions specified in the ASHRAE 93-2003 test standard lead to tests at unreasonably high inlet temperatures for many collectors on the market. The conditions specified in the standard indicate the larger heaters are necessary and, as a result, will make the tests more expensive. Beyond expense, increasing the temperature above 100°C or 212°F causes problems with regard to boiling and the related change in fluid properties.

The recommendations for determining the inlet temperature distribution are as follows:

1. Test at ambient temperature
2. The maximum inlet fluid temperature should be as high as possible, but not higher

than 10% below maximum operation temperature recommended by the collector manufacturer (as shown above, this will occur rarely), and test at this temperature;

3. Distribute the two other values of inlet temperatures equally between the two temperatures used in 1 and 2.

## Heaters

The relevant information to calculate the required heat power for the test facility is the maximum required temperature rise at a specified flow rate. The temperature of the hot water supply can be considered constant throughout the year, so the maximum temperature rise is determined by the maximum required inlet temperature during the test.

The temperature distributions prescribed by the test standard have been evaluated in the last preceding sections but the evaluation did not lead to reasonable values for the maximum required inlet temperature. We consider a maximum inlet temperature of 70°C (158°F) to be adequate. The following calculations are based on the first collector that will be tested at MATC. The calculated heater power will be sufficient to provide the defined maximum temperature of 70°C (158°F) at the fluid flow rate recommended by ASHRAE.

The considered collector has a relatively large area. The recommended flow rate for a specific collector depends on the collector area; a higher collector area leads to a higher flow rate. Hence, the heater power will be sufficient for most of the collectors on the market, as the required flow rate and as result the required heater power decrease for smaller collector areas. 147 out of the 148 collectors listed in “Ratings summary of OG-100 certified glazed collectors” in the “Summary of SRCC certified solar collector and water heating system ratings (October 2006)” have a smaller area than the considered collector. So with the heater power calculated in the following section all these collectors could be tested at an inlet temperature of 70°C (158°F).

The first collector that will be tested at MATC has an area of 7.2 m<sup>2</sup> (78 ft<sup>2</sup>). ASHRAE recommends a mass flow rate of 0.02 kg/s-m<sup>2</sup> (14.7 lb<sub>m</sub>/h-ft<sup>2</sup>). The density of water at 37.8°C (100°F) is 993 kg/m<sup>3</sup> (8.287 lb<sub>m</sub>/gal). So the volume flow rate  $\dot{V}$  should be adjusted to 0.0001451 m<sup>3</sup>/s (2.3 gpm). The following table shows the required power to heat up water at this flow rate from an inlet temperature  $T_{in}$  of 37.8°C (100°F) to the desired outlet temperature,  $T_{out}$ . The heat capacity  $c_p$  is assumed to be constant at 4.182 kJ/kg-K (1 Btu/lb<sub>m</sub>-F), losses to the surroundings are neglected. The power  $\dot{W}$  can now be calculated by

$$\dot{W} = \dot{V} \cdot \rho \cdot c_p \cdot (T_{out} - T_{in}) \quad (1.8)$$

and is shown for different outlet temperatures in Table 6.

Table 6: Required heat power for water flowing at 0.0001451 m<sup>3</sup>/s (2.3 gpm) entering the heater at 37.8°C (100°F)

$\Delta T$	$T_{out}$	$\Delta T$	$T_{out}$	$\dot{W}$
[C]	[C]	[F]	[F]	[kW]
11.1	48.9	20	120	6.7
16.7	54.4	30	130	10.0
22.2	60.0	40	140	13.4
27.8	65.6	50	150	16.7
33.3	71.1	60	160	20.1
38.9	76.7	70	170	23.4

During a test at MATC on Oct 25 2006, the heaters were tested to evaluate the calculations. The heater inlet temperature was 38.6°C (101.5°F); the heater outlet temperature was 48.9°C (120°F). The volume flow rate was measured to be 0.0001382 m<sup>3</sup>/s (2.19 gpm). Using the values same values for density and heat capacity as above and equation (1.8) yields a required power of 5.9 kW. This value can be compared with the electrical power provided to the heaters. The 3 heaters were operating at a voltage of 116.4 V and a current of 18.3 A, so the power was 6.4 kW. Possible reasons for the difference between the power values are thermal losses, which have been neglected and uncertain measurements of temperatures and flow rate, as the calibration of the instruments was still in progress during the first collector test.

Theoretically a heater power of 20.1 kW must be provided in order to achieve a maximum inlet temperature of 70°C (158°F) for the considered collector.

<sup>1</sup> ANSI/ASHRAE Standard 93-2003, *Methods of Testing to Determine the Thermal Performance of Solar collectors*. ISSN 1041-2336, ASHRAE, Inc., 2003, 1791 Tullie Circle, Ne, Atlanta, GA30329

<sup>2</sup> ASHRAE Standard 41.1-86 (RA 2001), *Standard Method for Temperature Measurement: Section on Temperature Measurements*. ASHRAE, Inc., 2001, 1791 Tullie Circle, Ne, Atlanta, GA30329